

Free Body Diagrams

Name:
 Period:
 Mr. Z.'s Physics Class
 Due: 11/29/05

We would like to be able to deal with situations where there is more than one object present and we need to know the forces acting on **every** object. We know already how to identify what forces are present:

- If two objects are in contact, each feels a **normal** force, \vec{F}_N , pushing away from where they touch.
- If two objects are sliding or trying to slide past each other, each feels a **friction** force \vec{F}_F resisting the sliding. The friction force has a strength of at most $F_F = \mu F_N$, where μ , the "coefficient of friction", is what fraction of the normal force the friction force should be, based on the slipperiness of the surface.
- If two objects are connected by a taut rope or string, each feels a **tension** force \vec{F}_T pulling in along the string.
- Every object feels a **gravity** force \vec{F}_g , also called its **weight**, whose strength is just the mass times the strength of gravity: $F_g = mg$.

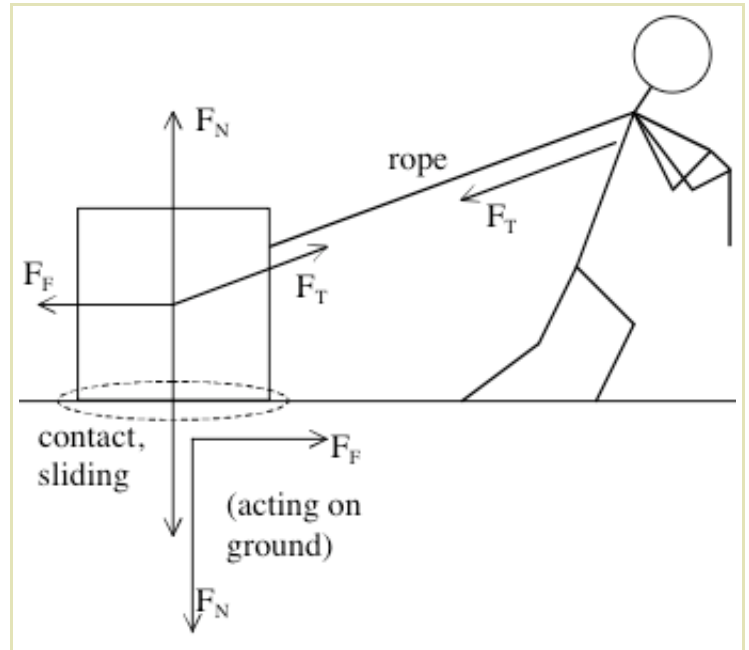

Notice that for all these forces, there are really two objects that the force acts on. Even gravity is a pair of forces: my gravity pulls up on the Earth as much as it pulls down on me. This relationship is summed up in Newton's Third Law: **Any time that an object A exerts a force \vec{F} on an object B, B exerts a force $-\vec{F}$ on A.**

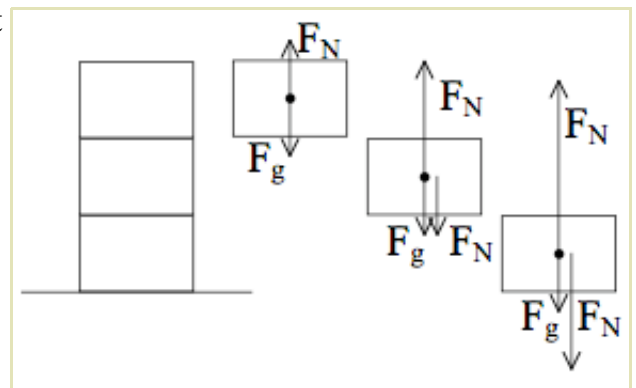

Sometimes, to make it easier to see what forces are acting on an object, we draw each object in the scene separately with all the forces that are acting just on it. This is known as a **free body diagram**. So, in the situation to the right, drawing the force diagram for the top block allows me to figure out the normal force it exerts on the next block, and so on.

1. Each ball has a weight of 5 N. Draw the free body diagram for each ball, with the vector form of each force.

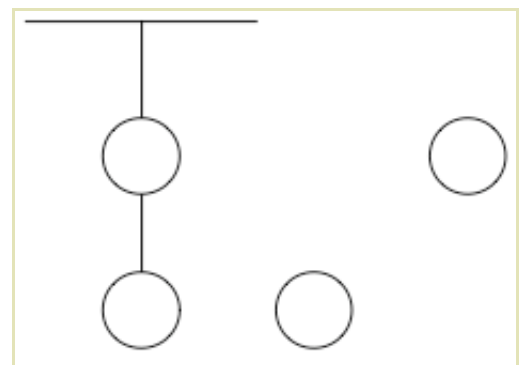

2. Assume that a car has only two wheels, and its weight rests equally on both. Draw a free body diagram for the car itself and for one of the wheels. You don't need to find the strength of forces; just draw and label the arrows.



3. In order to move forward, a car must turn its wheels. This creates friction with the ground.

- a) Draw force arrows showing how the car pushes on the ground, and how the ground pushes on the car. Also draw an arrow showing which direction the wheels are turning.

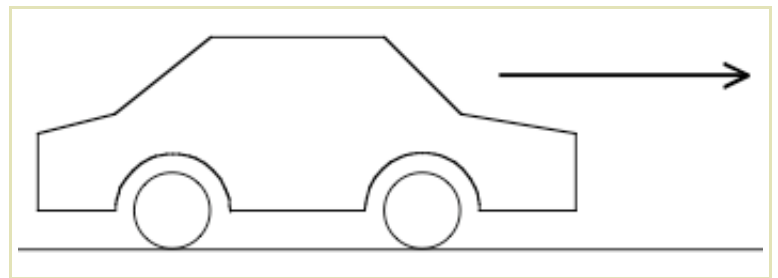

- b) What happens if the car tries to accelerate too fast and exceeds the maximum possible friction value?
4. If I am standing on the ground, what sort of force am I exerting on the ground, and how strong is it?
5. We've said before that a person standing on a floor with a μ of 0 cannot move except to fall down. This is like standing on perfectly slippery ice - he can't create any friction with the ground that would move him.

What could he do instead to escape?

